

# IS Multi-turn Gearbox Series

**rotork**<sup>®</sup>  
Gears

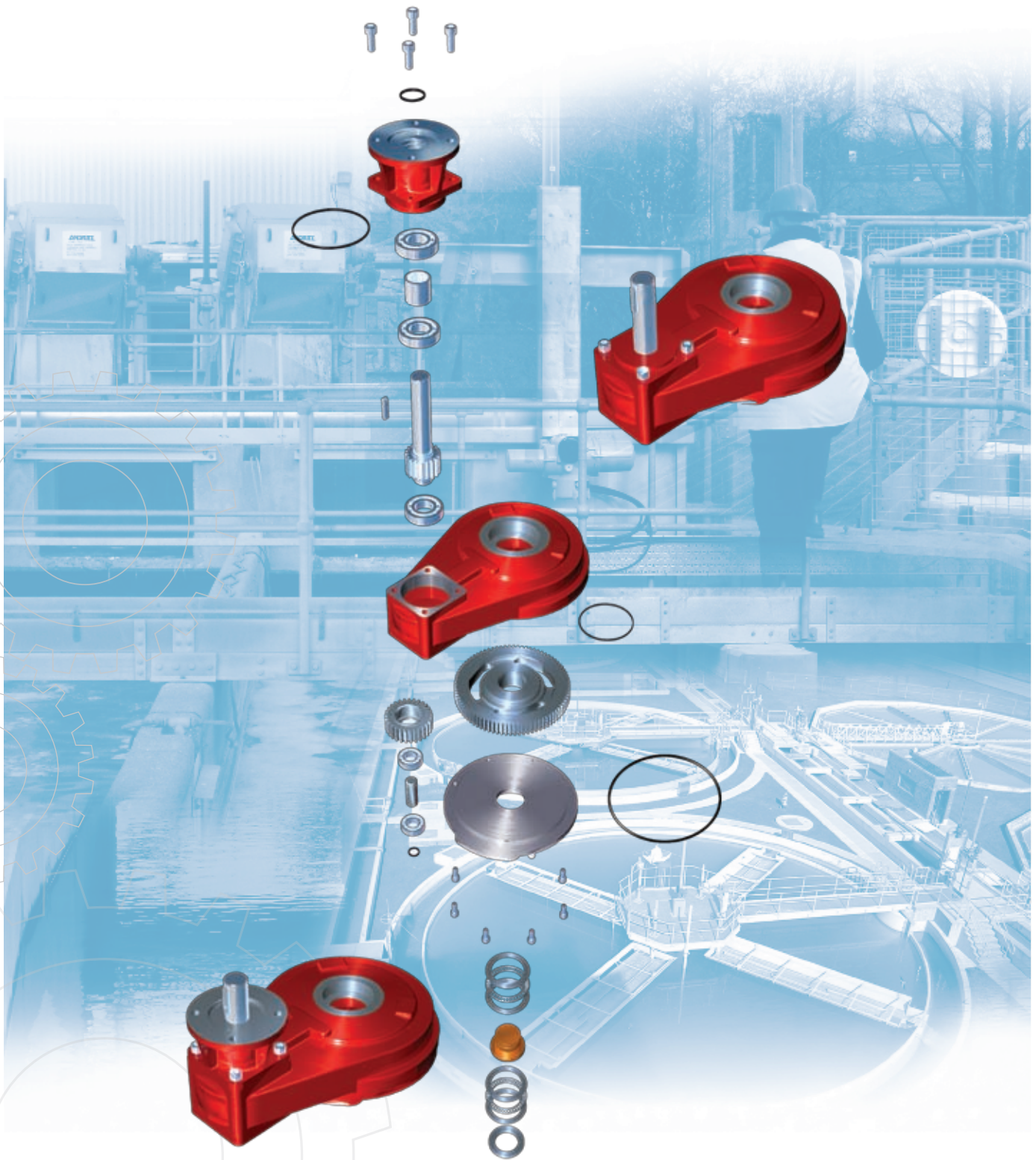

Cast Iron Housing Gearboxes - IS Multi-turn Gear Series

# IS Gearbox Series

## IS Multi-turn Gearbox Series

### Description

The IS series of multi-turn operators has been designed with customer stocking in mind, and features a removable output sleeve to facilitate spindle machining.

Operating temperature normally ranges from -40 °C to 120 °C, although other temperature ranges are available on request.

Standard input (for actuation) and output flanges are to ISO5211. However, equivalent standards such as DIN can be supplied.

### Application

Rotork Gears IS series operators are Multi-turn devices intended for the operation of gate, globe, sluice and penstock valves. The gearboxes are suitable for manual and motorised applications.

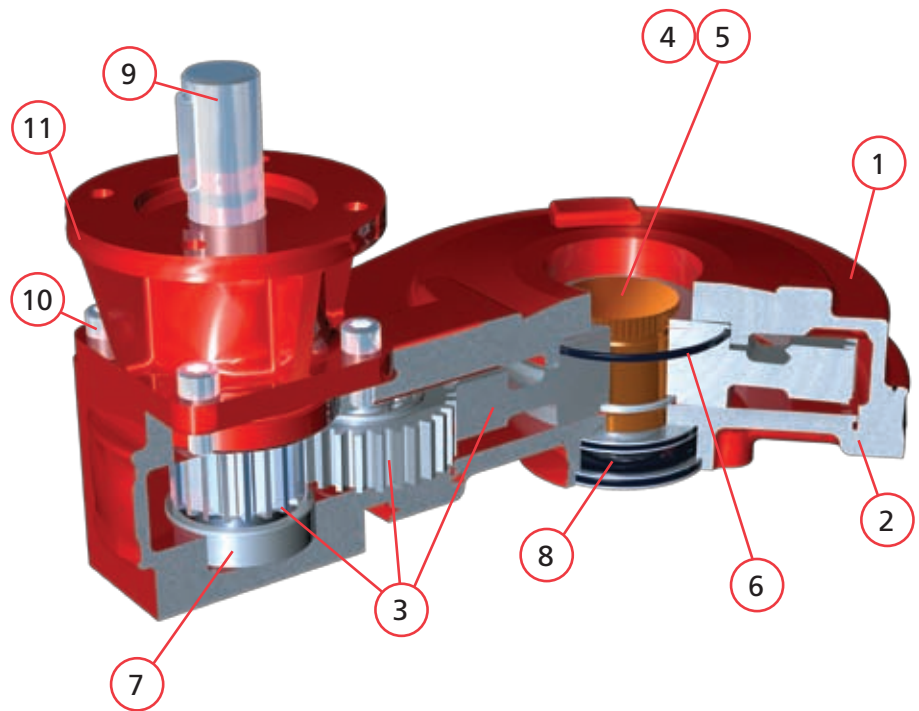

## Material specification for Rotork Gear IS Range of SPUR Gear Valve Operators.

### Features

- Totally enclosed gearing
- Grease filled for life & fully sealed
- Comprehensive gear ratios
- Removable output sleeve
- Spur and bevel combinations available
- Input gear mounted on ball bearings

### Options

- Upward or downward oriented input
- Auxiliary spur / bevel input reducers
- Input flanges for motorisation
- Two speed spur input reducers
- High & low temperatures
- Padlockable handwheels
- Nuclear
- IP68
- Buried duty
- Raw sewage

No.	Description	Material	UK Standard	USA Standard	DIN Standard
1	Gearcase (IS2 to IS7 & IS12 to IS14)	Cast Iron	BS1561 EN-GJL-250	ASTM A48 35B/40B	GG-25
	Gearcase (IS8 to IS11 & IS15 to IS20)	SG Iron	BS1563 EN-GJS-450-10	ASTM A536 65-45-12	GGG-40
2	Baseplate	SG Iron	BS1561 EN-GJS-450-10	ASTM A536 65-45-12	GGG-40
3	Gears	SG Iron Steel	BS1563 EN-GJS-700-2 BS970 605M36T	AISI/SAE 1010 or 4340	GGG-70
4	Output Sleeve A1	Steel	BS970 070M20	AISI/SAE 1023	C22
5	Output Sleeve A2	Aluminium Bronze	BS1400 AB2	ASTM B505 C95800	
6	Seals	Nitrile Rubber			
7	Input Shaft bearings	Ball Bearings			
8	Output Thrust Bearings	Needle Roller Bearings (with the exception of output sizes 14, 16, 18, 19 & 20 which has Roller Thrust Bearings).			
9	Input Shaft	Steel	BS970 605M36T	AISI/SAE 4340	42 MnMo 7
10	Fasteners	Steel	BS3692 & BS4168		
11	Input Housing	Cast Iron	BS1561 EN-GJL-250	ASTM A48 35B/40B	GG-25
	Grease	Renolit CL-X2			
	Finish	PE3 Grey Primer (other finishes available on request)			

Note: Because of the company's policy of continuous improvement, Rotork Gears reserves the right to change specification details without prior notice.

## Gearbox IS Series

### Input Flange Details

INPUT	FLANGE DIA. & THICKNESS	SHAFT DIA.	KEY DETAILS
F10 & FA10	Ø125 x 10	Ø20.00 - 0.05	6 x 6 x 40
F14 & FA14	Ø175 x 15	Ø30.00 - 0.05	8 x 7 x 40
F16 & FA16	Ø210 x 20	Ø40.00 - 0.05	12 x 8 x 55
F25 & FA25	Ø300 x 20	Ø50.00 - 0.05	14 x 9 x 55
F30	Ø350 x 20	Ø50.00 - 0.05	14 x 9 x 80
ROTORK G30	Ø418 x 20	Ø50.00 - 0.05	14 x 9 x 80

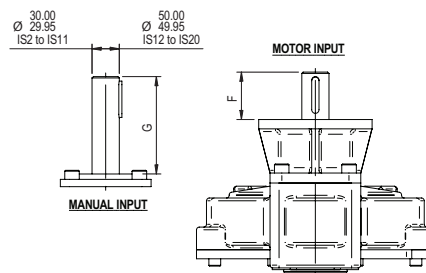
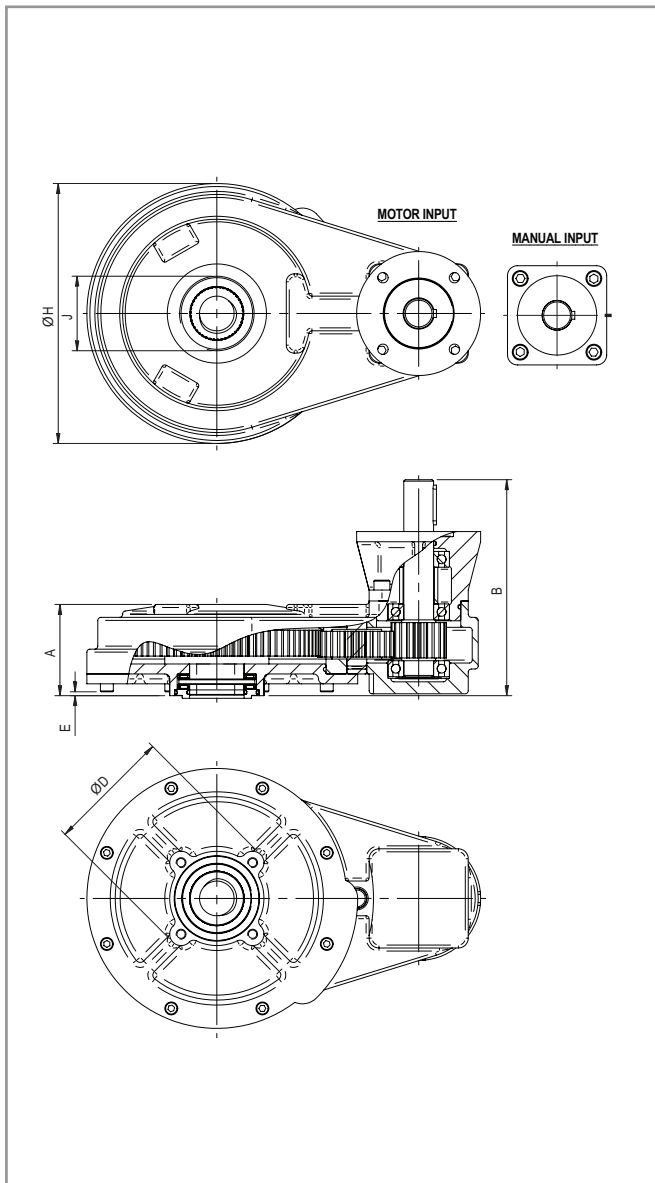

Gearbox	Max Bore Rectangular Key BS4235	Max Acme Thread (Inch)	Max Acme Thread (mm)	Weight (Kg)
IS2	40.0	1 3/4"	45	19
IS3	52.0	2 1/8"	55	20
IS4	40.0	1 3/4"	45	25
IS5	52.0	2 1/8"	55	30
IS6	52.0	2 1/8"	55	45
IS7	68.0	2 3/4"	73	50
IS8	68.0	2 3/4"	73	75
IS9	76.0	3 3/8"	86	82
IS10	76.0	3 3/8"	86	108
IS11	96.0	3 7/8"	100	122
IS12	96.0	3 7/8"	100	185
IS13	121.0	5"	127	220
IS14	130.0	5 7/8"	150	345
IS15	121.0	5"	127	270
IS16	130.0	5 7/8"	150	400
IS17	121.0	5"	127	580
IS18	130.0	5 7/8"	150	750
IS19	170.0	7 3/8"	190	810
IS20	206.0	8 3/4"	225	980

Gearbox	Ratio	A	B	C	ØD	E	F	G	ØH	J	Input Options	Output Options
IS2	1, 2 & 3:1	87	221	153	125	-5	51	113	172	2.5 BSP or NPT	F10 & F14	F10
IS3	1, 2 & 3:1	109	230	153	172	17	51	113	172	2.5 BSP or NPT	F10 & F14	F14
IS4	2, 3, 4 & 6:1	92	221	204	125	4	51	113	262	2.5 BSP or NPT	F10 & F14	F10
IS5	2, 3, 4 & 6:1	115	239	204	175	27	51	113	262	2.5 BSP or NPT	F10 & F14	F14
IS6	2, 3, 4, 6 & 8:1	119	235	305	166	4	51	113	330	3.5 BSP or NPT	F10, F14 & F16	F14
IS7	2, 3, 4, 6 & 8:1	120	236	305	200	5	51	113	330	3.5 BSP or NPT	F10, F14 & F16	F16
IS8	4, 6, 8, 10, 12 & 15:1	183	343	333	210	38	60	155	330	4 BSP or NPT	F10, F14, F16 & F25	F16
IS9	4, 6, 8, 10, 12 & 15:1	189	349	333	300	44	60	155	330	4 BSP or NPT	F10, F14, F16 & F25	F25
IS10	4, 6, 8, 10, 12 & 15:1	221	376	356	300	41	60	155	412	5 BSP or NPT	F14, F16 & F25	F25
IS11	4, 6, 8, 10, 12 & 15:1	242	397	356	350	62	60	155	412	5 BSP or NPT	F14, F16 & F25	F30
IS12	8, 10, 12 & 15:1	282	437	407	350	62	60	155	412	—	F14, F16 & F25	F30
IS13	8, 10, 12 & 15:1	298	453	407	410	78	60	155	520	—	F14, F16 & F25	F35
IS14	8, 10, 12 & 15:1	410	565	407	476	190	60	155	520	—	F14, F16 & F25	F40
IS15	10, 12 & 15:1	413	564	454	410	72	60	155	520	—	F14, F16 & F25	F35
IS16	10, 12 & 15:1	525	676	454	476	184	60	155	520	—	F14, F16 & F25	F40
IS17	6, 8, 10, 12, 15 & 24:1	483	663	610	410	72	90	185	705	—	F16, F25, F30 & F35	F35
IS18	6, 8, 10, 12, 15 & 24:1	595	775	610	476	184	90	185	705	—	F16, F25, F30 & F35	F40
IS19	6, 8, 10, 12, 15 & 24:1	647	827	610	476	236	90	185	705	—	F16, F25, F30 & F35	F40
IS20	6, 8, 10, 12, 15 & 24:1	710	890	610	555	299	90	185	705	—	F16, F25, F30 & F35	REQUEST

All dimensions in millimetres.

## Gearbox Selection Chart

Gearbox	Nominal Ratio					Exact Ratio					Manual Output Torque (Nm)	Max Manual Thrust (kN)	Motorised Output Torque (Nm)	Max Motorised Thrust (kN)	Mechanical Advantage							
	1	2	3	4	6	1.25	2.04	3.00	4.10	6.00					1.25	1.83	2.70	3.69	5.40			
IS2	1	2	3			1.25	2.04	3.00			508	54	406	53	1.250	1.830	2.700					
IS3	1	2	3			1.25	2.04	3.00			508	178	406	177	1.250	1.830	2.700					
IS4	2	3	4	6		2.12	3.00	4.10	6.00		850	54	678	53	1.900	2.700	3.690	5.400				
IS5	2	3	4	6		2.12	3.00	4.10	6.00		850	178	678	177	1.900	2.700	3.690	5.400				
IS6	2	3	4	6	8	2.00	3.00	4.00	6.00	8.00	1700	178	1355	177	1.800	2.700	3.600	5.400	7.200			
IS7	2	3	4	6	8	2.00	3.00	4.00	6.00	8.00	1700	356	1355	266	1.800	2.700	3.600	5.400	7.200			
IS8	4	6	8	10	12	15	4.01	6.10	7.95	10.20	12.26	15.03	2550	356	2033	266	3.600	5.490	7.156	9.180	11.030	13.520
IS9	4	6	8	10	12	15	4.01	6.10	7.95	10.20	12.26	15.03	2550	445	2033	355	3.600	5.490	7.156	9.180	11.030	13.520
IS10	4	6	8	10	12	15	4.04	6.11	7.81	10.17	12.11	14.66	5423	445	4067	355	3.633	5.500	7.025	9.156	10.900	13.194
IS11	4	6	8	10	12	15	4.04	6.11	7.81	10.17	12.11	14.66	5423	670	4067	500	3.633	5.500	7.025	9.156	10.900	13.194
IS12	8	10	12	15		8.09	9.99	11.83	15.15		10846	670	8135	500	7.280	8.993	10.649	13.632				
IS13	8	10	12	15		8.09	9.99	11.83	15.15		10846	1112	8135	834	7.280	8.993	10.649	13.632				
IS14	8	10	12	15		8.09	9.99	11.83	15.15		10846	1557	8135	1320	7.280	8.993	10.649	13.632				
IS15	10	12	15			9.86	12.00	15.00			19000	1112	16270	834	8.870	10.800	13.500					
IS16	10	12	15			9.86	12.00	15.00			19000	1557	16270	1320	8.870	10.800	13.500					
IS17	6					6.11					43385	1112	40800	834	5.500							
IS17	8	10	12	15	24	8.11	10.00	12.03	15.17	24.09	46100	1112	43386	834	7.300	9.000	10.820	13.650	21.680			
IS18	6					6.11					43385	1557	40800	1320	5.500							
IS18	8	10	12	15	24	8.11	10.00	12.03	15.17	24.09	46100	1557	43386	1320	7.300	9.000	10.820	13.650	21.680			
IS19	6					6.11					43385	2242	40800	1668	5.500							
IS19	8	10	12	15	24	8.11	10.00	12.03	15.17	24.09	46100	2242	43386	1668	7.300	9.000	10.820	13.650	21.680			
IS20	6					6.11					43385	3342	40800	2224	5.500							
IS20	8	10	12	15	24	8.11	10.00	12.03	15.17	24.09	46100	3342	43386	2224	7.300	9.000	10.820	13.650	21.680			

## Dimensions

Type	øH	K	N
F200	200	75.5	3
F300	300	100.5	3
F400	400	100.5	4
F500	500	100.5	4
F600	600	100.5	4
F700	700	100.5	6
F800	800	100.5	6
F900	900	100.5	6
F1000	1000	100.5	6
F1100	1100	100.5	6
F1200	1200	100.5	8

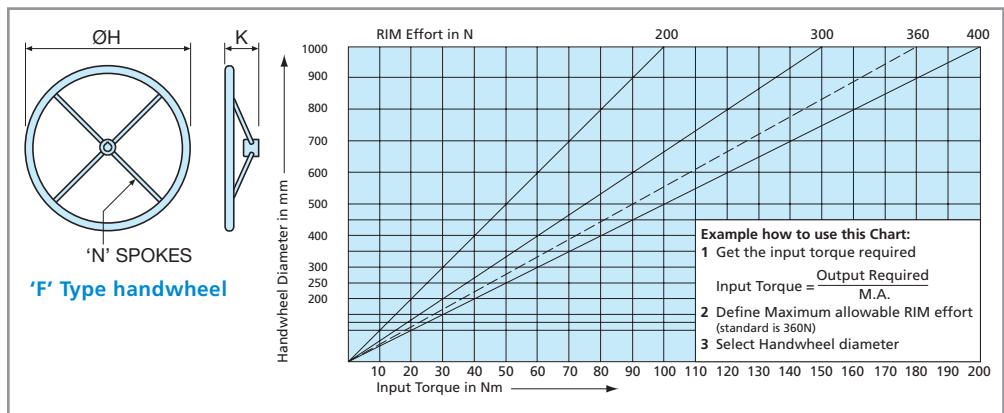

**Rotork Gears BV**  
Nijverheidstraat 25  
7581 PV Losser  
P.O. Box 98  
7580 AB Losser  
The Netherlands

tel: +31 (0)53 - 5388677  
fax: +31 (0)53 - 5383939  
email: info@rotorkgears.nl

**Rotork Gears UK**  
Regina House  
Ring Road  
Bramley, Leeds  
West Yorkshire LS13 4ET  
England

tel: +44 (0)113 2057276  
fax: +44 (0)113 2563556  
email: sales@rotorkgears.co.uk

**Rotork Valvekits**  
Brookside Way  
Nunn Park  
Huthwaite  
Nottinghamshire NG17 2NL  
England

tel: +44 (0)1623 440211  
fax: +44 (0)1623 440214  
email: sales@rotorkvalvekits.co.uk

**Rotork Gears S.R.L.**  
via Olona, 65/67  
20015 Parabiago (MI)  
Italy

tel: +39 0331 552128  
fax: +39 0331 553147  
email: info@rotorkgears.it

**Rotork Gears Shanghai**  
No. 260 Lian Cao Road  
Xin Mei Urban Industrial Park  
Min Hang District  
Shang Hai 201108  
China

tel: 0086-21-64348388  
fax: 0086-21-64348366  
email: info@rotorkgears.com.cn

A full listing of our worldwide sales and service network is available on our website at [www.rotork.com](http://www.rotork.com)

As part of a process of on-going product development, Rotork reserves the right to amend and change specifications without prior notice.

Published data may be subject to change.

For the very latest version release, visit our website at [www.rotork.com](http://www.rotork.com)

The name Rotork is a registered trademark. Rotork recognizes all registered trademarks. Published and produced in the UK by Rotork Controls Limited. POWSH1008