

rotork[®] Fluid Systems

GO Range

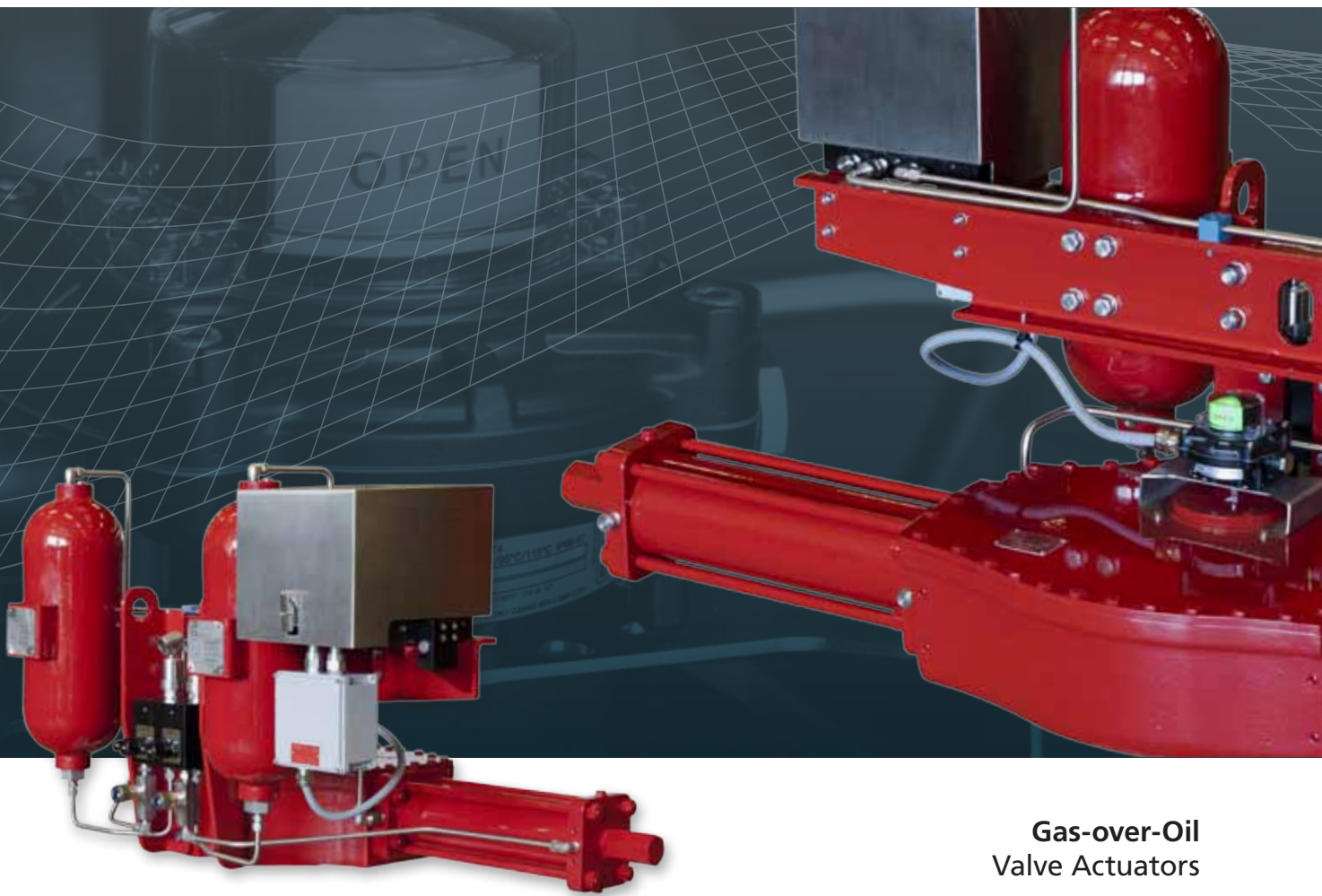

**Gas-over-Oil
Valve Actuators**

Redefining Flow Control

Rotork Actuators – Quality Controlled

Rotork is a global leader in valve actuation technology. We provide a comprehensive range of valve actuators, controls and associated equipment, as well as a variety of valve actuator services including commissioning, preventive maintenance and retrofit solutions.

Rotork Fluid Systems specialises in the production and support of fluid power actuators and control systems. We are dedicated to providing the marketplace with the latest technology, consistently high quality, innovative design, excellent reliability and superior performance.

Rotork Fluid Systems maintains dedicated engineering groups for Applications, Product Improvement and New Product Development so that our customers can gain all the benefits that ever advancing technologies have to offer and to ensure our efforts are in step with the continually evolving needs of our customers.

Most importantly, we have a long-standing commitment to meeting the special needs of a wide range of applications including: oil and gas exploration and transportation; municipal water and wastewater treatment; power generation; and the chemical and process industries.

With over fifty years of engineering and manufacturing expertise, we have tens of thousands of successful valve actuator installations throughout the world.

GO Range – Gas-over-Oil Actuators

Reliability by Design

Every Rotork Fluid Systems actuator is built to provide long and efficient service with a minimum of maintenance. The design, engineering and materials used in the construction ensure optimum performance even in the harshest of environments. Our modular construction design facilitates stocking by allowing a minimal amount of components to meet a wide range of valve torque requirements.

Our GO Range of pipeline actuators is designed to use pipeline gas as the motive power source. The gas is delivered to oil tanks that convert the gas into hydraulic pressure. This pressurised hydraulic oil is used to drive our industry recognised and proven scotch yoke quarter-turn or linear actuators. Using pressurised oil as the driving fluid provides powerful and smooth actuator control and isolates the cylinder from pipeline gas. This prevents contaminants from entering the hydraulic cylinder, eliminating corrosion and seal deterioration, and extending actuator life.

The compact, modular gas control manifolds employ poppet style control valves – a reliable design trusted throughout the industry – and are available in fail-safe versions. The standard gas control systems are complemented with a variety of Rotork Fluid Systems designed optional equipment and functions including Line Break, Low Pressure Close, and High Differential Inhibit. Operation is simple and intuitive.

Rotork provides GO actuators for a wide variety of end users in some of the most demanding environments. We have experience designing and supplying direct gas actuators to many end-user specifications including: NIGC, BOTAS, NIOC, GSPL KOC, PEMEX and BP.



GO Range Quarter-Turn and Linear Actuators

Quarter-Turn Actuators



Linear Actuators



Output

Quarter-turn maximum torque 600,000 Nm / 5,300,000 lbf-in.

Linear maximum thrust 5,000,000 N / 1,100,000 lbs.

Higher torque and thrust outputs are available upon request.

Temperature Range

Standard: -29 to 60 °C (-20 to 140 °F).

Low Option: -46 to 40 °C (-50 to 104 °F).

Hazardous Area Approvals

Standard: ATEX - II 2G EEx de IIB T4.

Options: IEC - Ex de IIB T4; Explosionproof Class 1, Division 1, Groups C&D.

Other approvals available upon request.

Standard Features and Benefits

- Scotch yoke quarter-turn actuators with either symmetric or canted yoke designs for optimum sizing of actuator to valve.
- Actuators are IP66M/67M third-party certified and approved for environmental protection.
- Actuators are CE and ATEX 94/9/CE third-party certified and approved.
- Chromium-plated piston rod and electroless nickel-plated cylinder to provide enhanced durability of critical sealing surfaces.
- Working pressure 10 to 105 barg (145 to 1,500 psig) – higher on application.
- Manual hand pump for emergency or local operation.
- Controls designed to operate at full pipeline pressure, eliminating possible pressure regulator failure.
- Modular and compact integrated manifold design reduces fittings and potential leakage.
- Local control via lever-operated poppet valves on the multi-function manifold.
- Standard GO tanks are designed, manufactured and tested according to ASME VIII Div. 1.
- Stainless steel pressure gauge to measure gas supply pressure with psi / bar scale.
- Particulate filter with a stainless steel element is included as standard. The element is easily removable and cleanable.
- Stroke time is adjusted via two hydraulic flow control valves providing smooth and precise speed control.

Optional Features

- Pressure sensing valves with optional manual reset to monitor pipeline pressure.
- Pressure differential valves with optional manual reset to monitor the differential across the valve.
- Linebreak detection safety systems sensing pipeline pressure drop over time.
- ESD (emergency shutdown) control configurations to suit specific customer shutdown logic requirements.
- Actuator torque limiting devices for the protection of the valve or drive train.
- Custom gas filtration.
- Lockable control cabinet in painted carbon steel, or optional stainless steel.
- Pressure vessel certification including ASME U-Stamp, PED 97/23/EC – other approvals on application.

Gas-over-Oil Control Systems

A comprehensive range of control systems and schematics have been developed to meet the requirements of end user gas-over-oil applications.

The Rotork standard gas-over-oil schematics are listed below. Please contact Rotork Fluid Systems for further options.

Gas-over-Oil Schematics

Schematic	Local Manual	2-Way Electric Remote	Line Break	High Differential Open Inhibit	Low Pressure Close
GO700-001	✓				
GO800-001	✓	✓			
GO702-001	✓		✓		
GO802-001	✓	✓	✓		
GO803-001	✓	✓		✓	
GO807-001	✓	✓		✓	✓
GO701-001	✓				✓

Parts List for GO Schematics

Item	Description	Qty.
1	Rotork Double Acting Actuator	1
2	End-of-Travel Limit Switch Housing (See Note)	1
4a	3-Way Pilot Valve (Close)	1
4b	3-Way Pilot Valve (Open)	1
5a	Solenoid 3/2 NC Valve (Close)	1
5b	Solenoid 3/2 NC Valve (Open)	1
6	Gas Vent	1
8	Gas Shuttle Valve	1
10	Gas Pressure Gauge (Supply Line)	1
14	Inline Gas Filter With Drain (40 micron)	3
21	Close Limit Valve	1
26	GO Tank	2
28	Hydraulic Manual Override Block Including:	
28a	3/2 Hand Operated Valve	2
28b	Hand Pump	2
28c	Unidirectional Flow Regulator	2
31	Tank Drain Valve	1
32	Gas Filter	1
33	Reference Tanks	1
34	Isolation Valve	1
35	Check Valve	2
36	Calibrated Orifice	1
37	Gas Filter	1
40	3/2 Differential Pressure Switch	1
50	L/R Selector Switch (Optional)	1
51	Flow Regulator Valve	1
55	3/2 Pilot Hand Operated Valve	1

Local Manual Operation

Depress hand lever (5a) to close or (5b) to open the valve actuator.

Remote Operation

Energise solenoid (5a) to close or (5b) to open the valve actuator.

Line Break

Line Break sensor (40) is connected to the pipeline and to the reference tank (33). When the rate of pressure drop in the pipeline exceeds the set point, the close poppet valve (4a) is piloted, causing the valve actuator to move to the close position. To enable opening after a line break trip, depress manual reset valve (55).

Note: 2-off travel limit switches are used to de-energise the solenoid when the actuator reaches end of travel.

Valves are shown de-energised and in the fail position.

Legend

Solenoid Connection	-----
High Pressure Gas Line	=====
Hydraulic Fluid Line	=====H=====

GO Schematics

GO 800-001 2-Way Electric Remote Operation & Local Manual Control

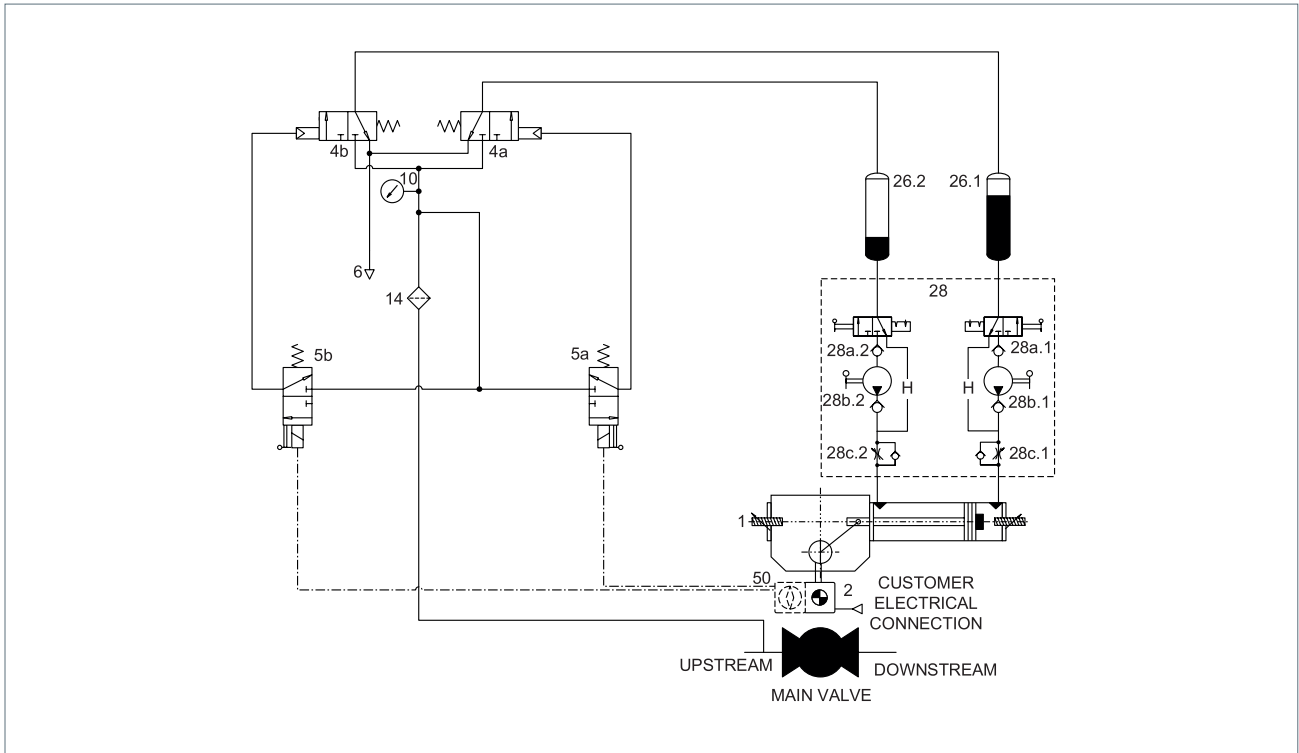

GO 802-001 Line Break, 2-Way Electric Remote & Local Manual Control

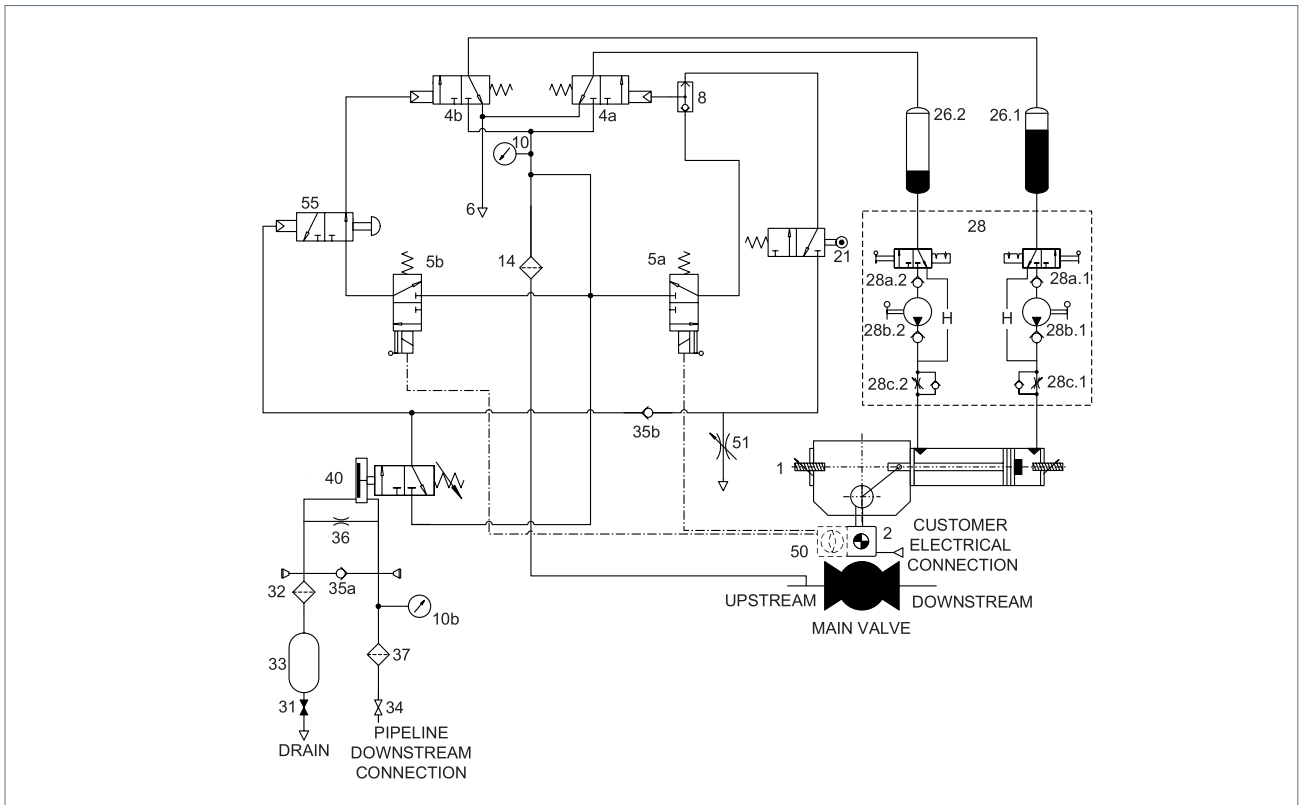

Key Control Components

Complementing the modular design of our gas-over-oil systems are the Rotork designed and manufactured control options ranging from simple local/remote pilot operated valves to pressure sensing and linebreak controls.

At the centre of our gas-over-oil systems is our multi-function manifold block. Integrating gas control functions, the high-pressure, high-flow manifold system allows us to configure a wide variety of control options. We utilise a dedicated pump for each direction to prevent leakage or contamination between the gas-over-oil tanks. The manifold has the facility for a high-flow hand pump, pressure relief and a locking handle for safe commissioning. Both high- and low-pressure control logic designs are available.

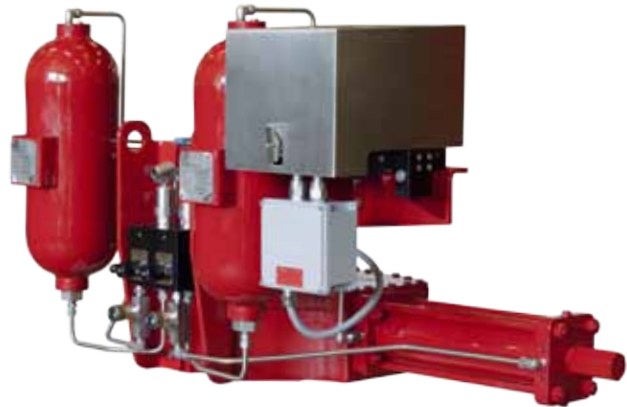

Multi-function Manifold Block

- Integral gas filter.
- Leak-free high-flow poppet valve design.
- Anodised aluminium construction.
- Tamper-proof cover (optional).

Hand Pump Override

- Volume and effort required selected to suit actuator and valve.
- Two displacements available to suit actuator size.
- Selector valves to permit local operation.
- Dual hand pumps eliminate leakage between GO tanks.
- Flow control valves included to adjust stroke time in each direction.

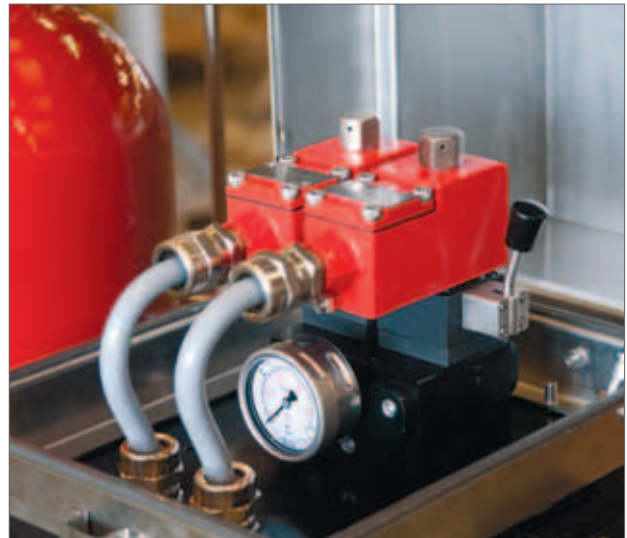

Available Options

Optional Extras

Dehydrator / Filter

A coalescing filter assembly with purge valve to facilitate removal of water from incoming power gas.

High / Low Pressure Select

This option provides two gas connection ports, one for the upstream side of the valve, and the other for the downstream side. Both connections are fed to a set of valves that select the higher or lower of the two.

Auxiliary N2 Connection

A second inlet gas connection that allows the user to connect a nitrogen supply for test.

Torque Limiting Device (TLD)

A device that limits the actuator maximum torque output to protect the actuator and/or valve stem from damage in the event of overpressure.

High Differential Open Inhibit

Automatic inhibition of opening, when the difference of pressure between upstream and downstream sides of the valve exceeds a set point. This can be achieved pneumatically or electrically.

Low Pressure Close

Automatic closure of the valve when the pressure in the pipeline drops below a set point.

Line Break

Automatic closing of the valve when the rate of pressure drop in the pipeline is greater than a set point.

Local / Remote Selector

A manual selector to allow the local user to place the actuator in local mode, thus taking priority over remote signals. This can be achieved pneumatically or electrically.

Electric ESD

A special ESD solenoid valve is added to the circuit, and when it is de-energised, the actuator moves to the fail-safe position.

Electrical Pressure Switch

A pressure switch is placed in the circuit to provide electrical indication when the pressure drops below a set point.

Manual Override Indication Switches

A switch is placed on the manual override selector to provide electrical indication when the actuator has been placed in local hand-pump mode.

High Pressure Ball Valve

Lockable valves are available to provide system isolation during maintenance.

Fire Protection Systems

Rotork Fluid Systems actuators and control systems can be customized to withstand exposure both to fire and very high environmental temperatures. A range of fire-proof systems is available that include flexible protective jackets, intumescent coatings and rigid enclosure systems.

For further information on Rotork's fire protection solutions, consult publication PUB000-004.



rotork® Site Services

Rotork Site Services provides a comprehensive range of service products, each specifically tailored to meet customers' requirements.

Emergency and Planned Service encompasses installation, commissioning, upgrading, installation of control systems, troubleshooting and repair of damaged or deteriorating assets. Actuator Overhauls are performed in Rotork workshops to bring long service units back to guaranteed 'as new' condition. Health Checks enable customers to prioritise maintenance and replacement planning whilst Preventative Maintenance enhances the integrity of actuators to maximise plant utilisation.

Rotork Site Services has a wealth of experience in Retrofitting new actuators to valves, penstocks and dampers installed on existing plant, as well as the factory assembly of new valves and actuators for plant upgrades and extensions. Capabilities for Extended Scope Projects include surveys, design, procurement, manufacturing and commissioning to cover the broad scope of activities surrounding actuation projects.

Visit www.rotork.com to identify your nearest Rotork Site Services centre.



Electric Actuators and Control Systems
Fluid Power Actuators and Control Systems
Gearboxes and Gear Operators
Precision Control Instruments
Projects, Services and Retrofit



UK
Rotork plc
tel +44 (0)1225 733200
fax +44 (0)1225 333467
email mail@rotork.com

A full listing of our worldwide sales and service network is available on our website.

www.rotork.com

PUB017-001-00
Issue 04/12

Formerly F301E. As part of a process of on-going product development, Rotork reserves the right to amend and change specifications without prior notice. Published data may be subject to change. For the very latest version release, visit our website at www.rotork.com
The name Rotork is a registered trademark. Rotork recognises all registered trademarks.
Published and produced in the UK by Rotork Controls Limited. POWTG0412